



ISTRUZIONI DI MONTAGGIO

IT

FITTING INSTRUCTIONS

EN

NOTICE DE MONTAGE

FR

IB BOX INC206

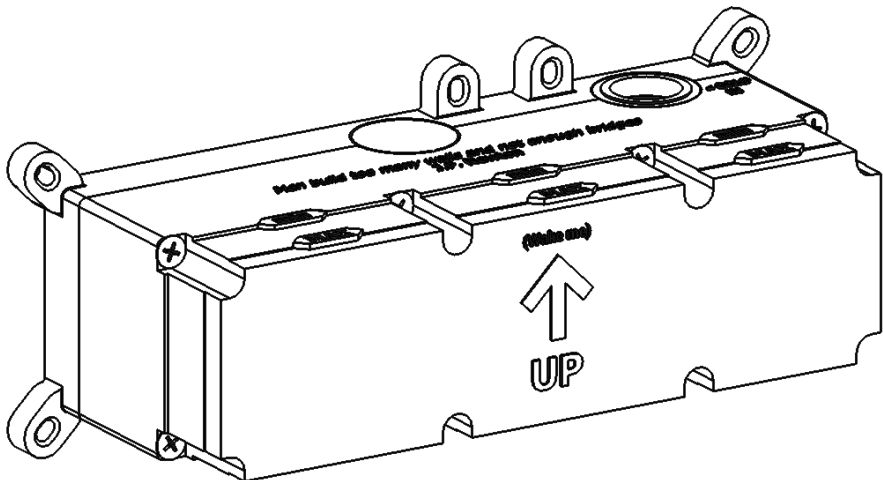

Miscelatore lavabo due fori a parete e idroscopino
Wall mounted washbasin mixer and shut off
Mitigeur lavabo mural et ensemble hygiénique



WE ARE IB

DATI TECNICI

Pressione dinamica MIN: 0.5 bar

Pressione MAX di esercizio: 5 bar

Pressione di esercizio raccomandata: 1-5 bar

Temperatura MAX acqua calda: 80°

NORME DI INSTALLAZIONE, MANUTENZIONE E VERIFICHE PRELIMINARI

Perchè il suo apparecchio funzioni nella maniera corretta e possa durare nel tempo, occorre che vengano rispettate le modalità di installazione e manutenzione illustrate in questo opuscolo. Affidarsi ad un idraulico qualificato. Assicurarsi che l'impianto sia stato liberato da tutti i detriti e impurità esistenti.

Si raccomanda di utilizzare un riduttore di pressione, se all'interno dell'impianto si hanno pressioni statiche superiori a 5 BAR.

Si raccomanda anche l'utilizzo di un addolcitore.

INSTALLAZIONE

Fig. 1 + Fig. 3: Posizionare il corpo miscelatore nell'alloggiamento realizzato nella parete, ponendo particolare attenzione ai riferimenti per la posa MIN e MAX stampati sul carter di protezione. **N.B.:** i riferimenti MIN e MAX sono intesi a parete finita, compreso di rivestimento.

Fig. 2: Estrarre i tappi in plastica ed allacciarsi alle tubazioni della rete idrica. é consigliabile utilizzare PTFE per garantire la tenuta al filetto.

Fig. 4: Stabilizzare il corpo all'interno della parete individuando, con l'ausilio di una livella a bolla, il corretto posizionamento.

Fig. 5: Dopo aver collegato il corpo incasso all'impianto, aprire i rubinetti d'arresto e verificare la mancanza di perdite nei collegamenti all'impianto.

Fig. 6: Murare l'incasso diminuendo le dimensioni dell'alloggio fino a filo del carter. Evitare di coprire le viti di bloccaggio scatola.

ATTENZIONE: Verificare a parete finita, compreso di rivestimento, di rientrare nelle misure minime e massime di incasso indicate sul carter. L'impermeabilizzazione del muro a discrezione dell'installatore.

Completati i lavori richiudere i rubinetti d'arresto non lasciando l'impianto in pressione.

TECHNICAL DATA

Minimum dynamic pressure: 0.5 bar

Maximum operational pressure: 5 bar

Recommended operational pressure: 1-5 bar

Maximum hot water temperature: 80°

INSTALLATION, MAINTENANCE AND PRELIMINARY CHECKING PROCEDURE

To ensure that the mixer tap unit functions correctly and lasts over time, the installation and maintenance procedures illustrated in this leaflet must be complied with. Have all work done by a qualified plumber. Ensure that all debris and dirt have been removed from the system.

It is recommended to use a pressure reducer, if inside the waterpipes there are static pressure superior 5 bar.

The use of a water softener is recommended.

INSTALLATION

Fig. 1 + Fig. 3: Place the body of the mixer tap unit in the cavity provided in the wall, taking care to refer to the MIN and MAX installation markings printed on the protective cover. N.B.: the MIN and MAX markings refer to the finished wall, complete with tiles.

Fig. 2: Remove the plastic plugs and connect to the system pipes. PTFE should be used to ensure watertight seals on the threads.

Fig.4: Secure the unit inside the wall, using a spirit level to position it correctly.

Fig. 5: After connecting the built-in body to the system, open the stopcocks and check for leaks in the connections to the system.

Fig. 6: Wall the box by reducing the size of the hole to the level of the carter. Avoid covering the box locking screws.

WARNING: Check with the finished wall, including the coating, to return to the minimum and maximum installation dimensions indicated on the carter.

After completing the works, close the stopcocks. Don't leave the system under pressure.

CARATÉRISTIQUES TECHNIQUES

Pression dynamique mini: 0.5 bar
Pression maxi d'exercice: 5 bar
Pression d'exercice recommandée: 1-5 bar
Température maxi eau chaude: 80°

NORMES D'INSTALLATION, D'ENTRETIEN ET VÉRIFICATIONS PRÉLIMINAIRES

Pour que votre appareil fonctionne correctement et dure dans le temps, il est nécessaire de respecter les modalités d'installation et d'entretien illustrées dans cet opuscule. Demander l'intervention d'un plombier qualifié. Vérifier que l'installation est libre de tous débris et de toutes impuretés.

Il est recommandé d'utiliser un réducteur de pression en cas de pressions statiques supérieures à 5 bar.

L'utilisation d'un adoucisseur est également recommandée.

INSTALLATION

Fig. 1 + Fig. 3: Positionner le corps du mélangeur dans le logement pratiqué dans le mur en tenant compte des références MIN et MAX imprimés sur le carter de protection. N.B.: les références MIN et MAX tiennent compte du mur fini, revêtement compris.

Fig. 2: Retirer les bouchons en plastique et effectuer le raccordement aux conduites du réseau. Il est conseillé d'utiliser PTFE pour garantir l'étanchéité des filetages.

Fig.4: Stabiliser le corps à l'intérieur du mur en s'aidant d'un niveau à bulle en vue d'un positionnement correct.

Fig. 5: Après avoir connecté le corps encastrés au système, ouvrez les robinets d'arrêt et vérifiez qu'il n'y a pas de fuites dans les connexions du système.

Fig. 6: Murer la boîte en réduisant la taille du logement jusqu'au niveau du carter. Évitez de couvrir les vis de verrouillage du boîtier.

ATTENTION: Vérifiez à mur fini, y compris le revêtement, que les dimensions d'installation minimales et maximales indiquées sur le carter soient respectées.

Une fois les travaux terminés, fermez les robinets d'arrêt. Ne laissez pas le système sous pression.

Per parte esterna (For external part) 206 / 207 / 706

Fig. 1

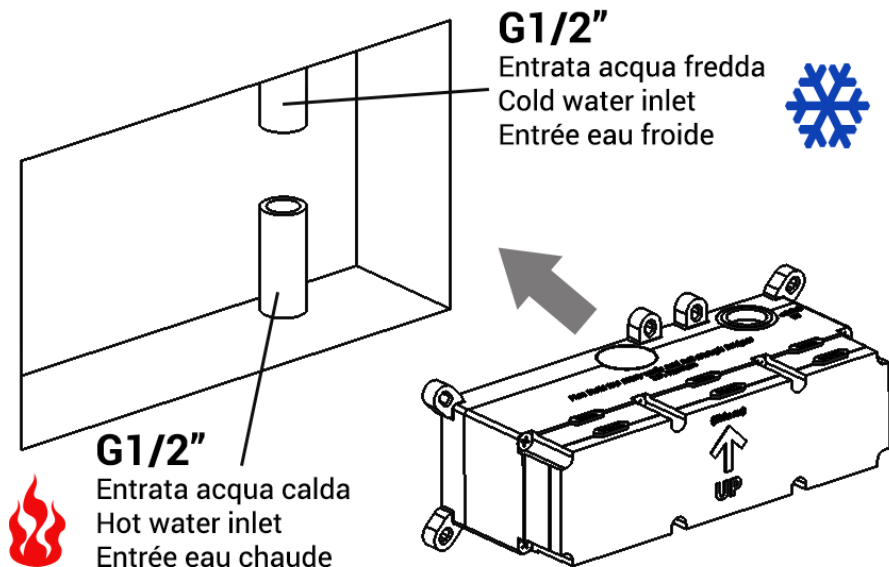

Fig. 2

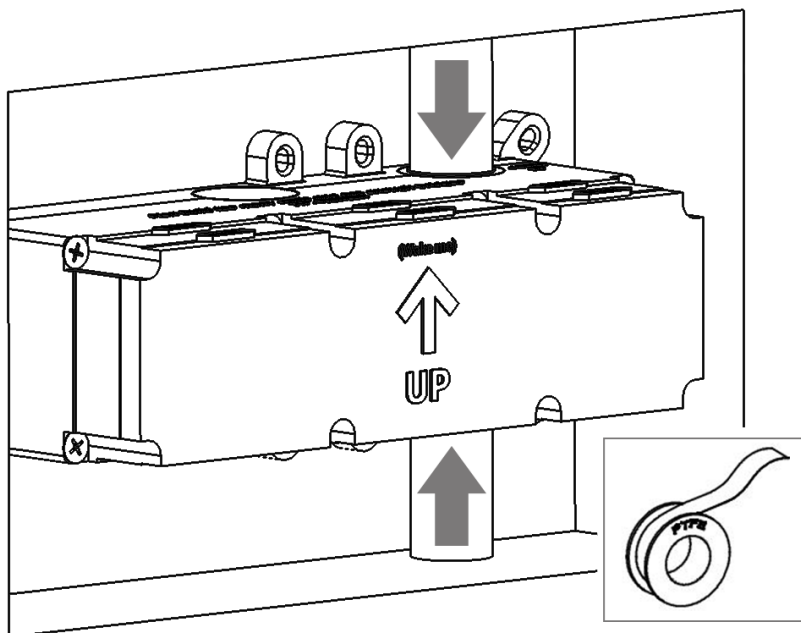

Fig. 3

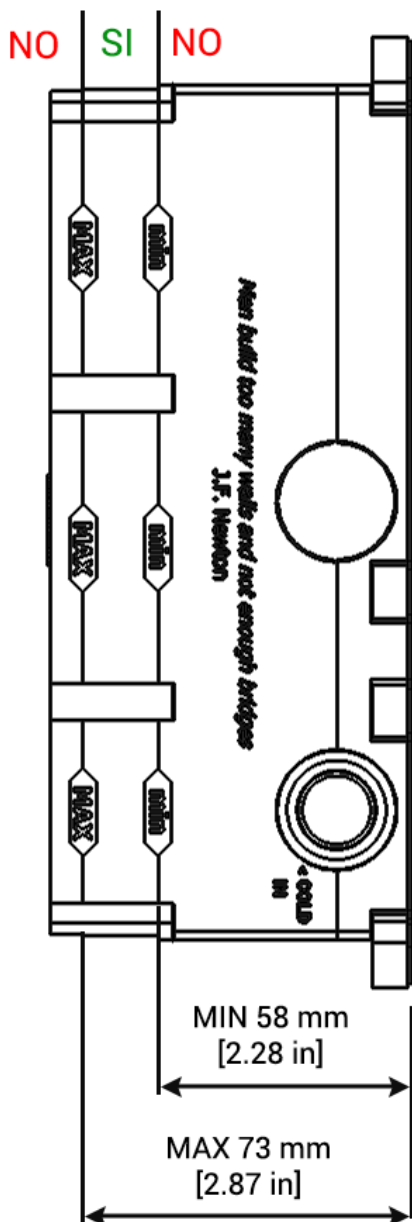
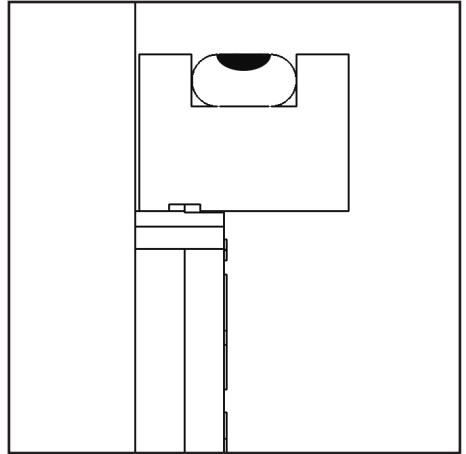
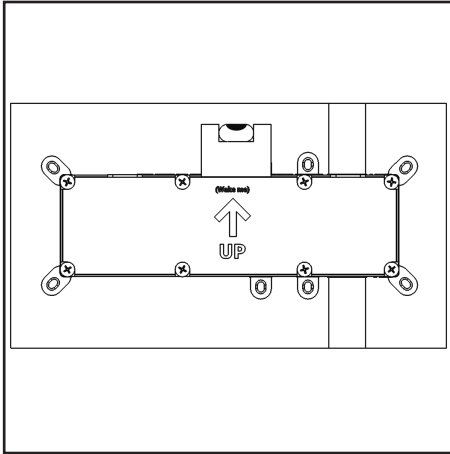
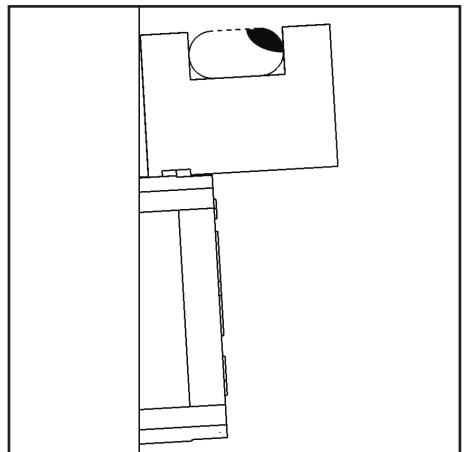
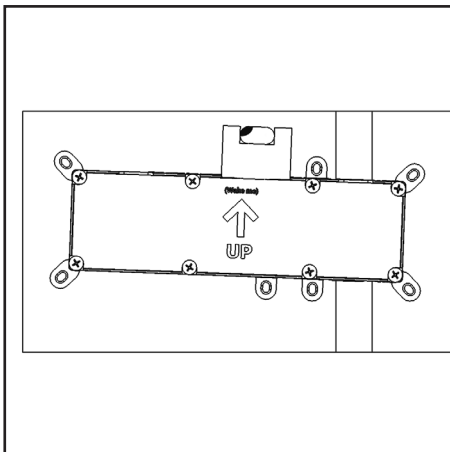

Fig. 4

SI, YES, OUI



NO



Per parte esterna (For external part) 206 / 207 / 706

Fig. 5

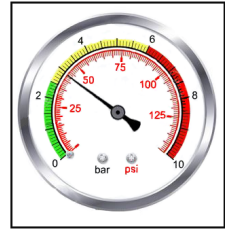
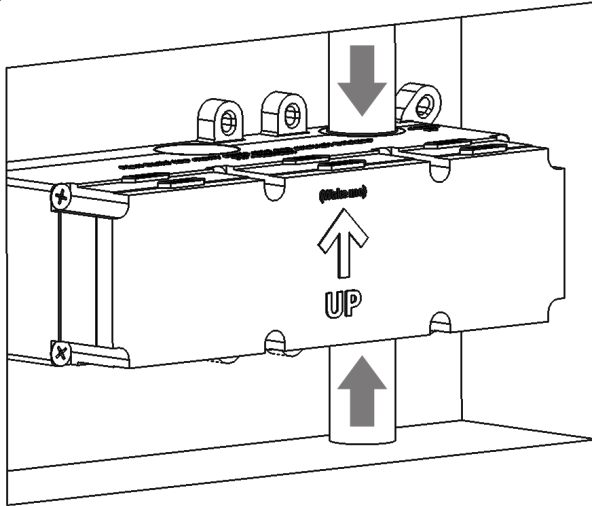
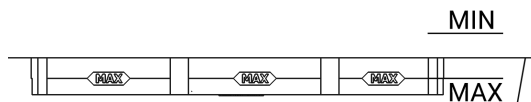
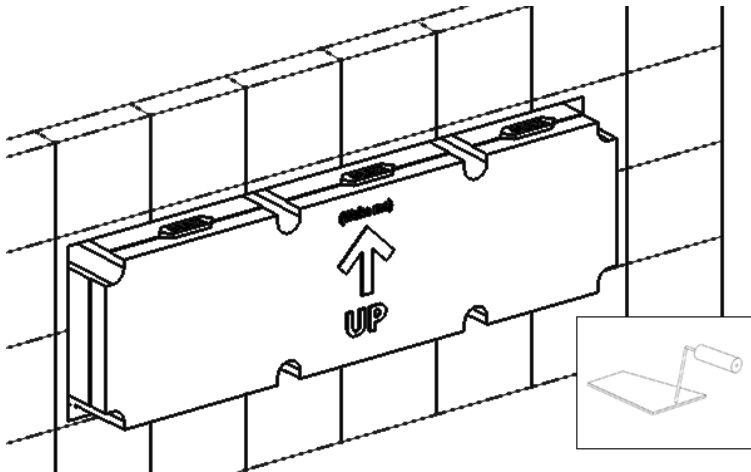
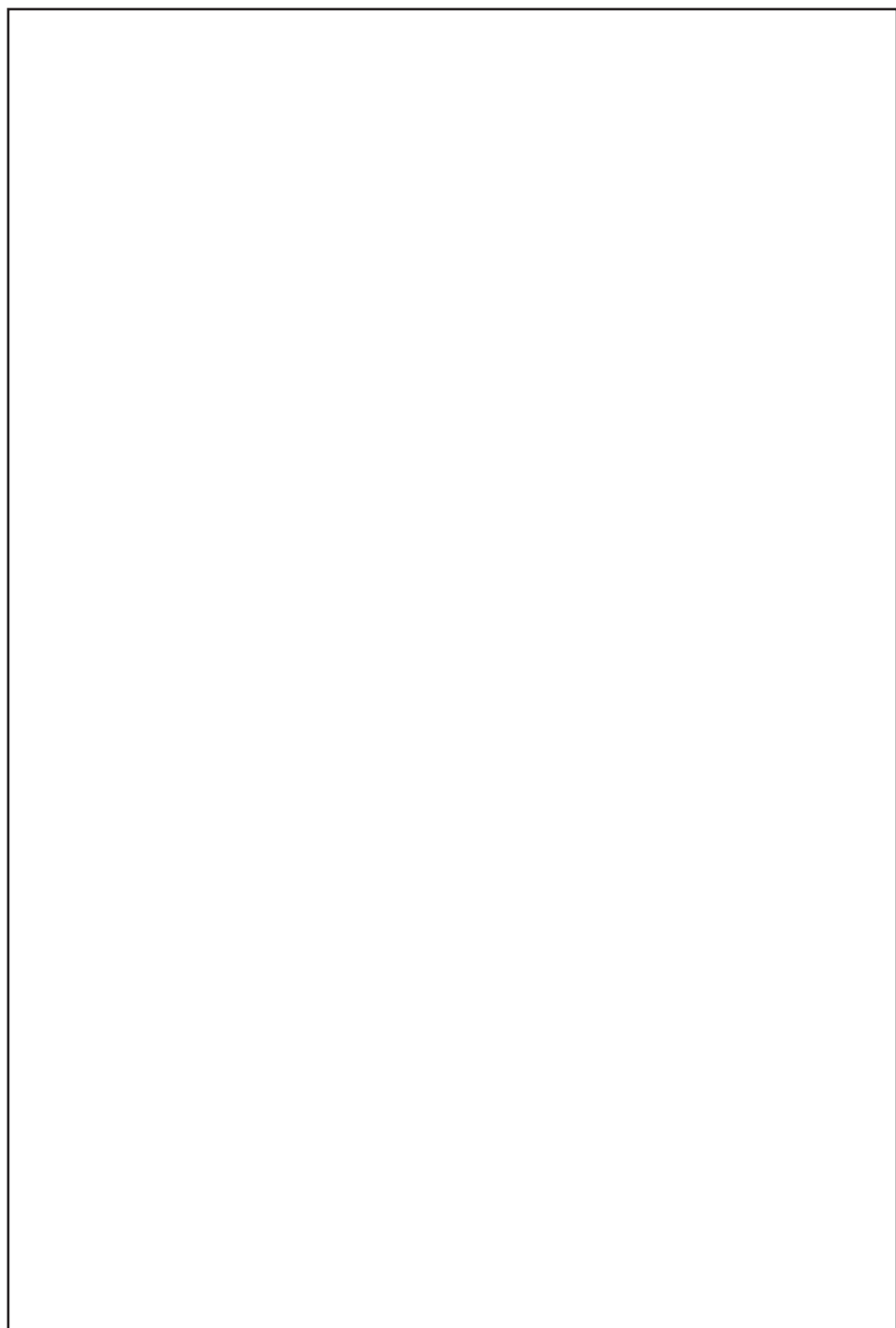

Fig. 6



Parete finita
Finish wall
Paroi finie



DATI TECNICI

Pressione dinamica MIN: 0.5 bar

Pressione MAX di esercizio: 5 bar

Pressione di esercizio raccomandata: 1-5 bar

Temperatura MAX acqua calda: 80°

NORME DI INSTALLAZIONE, MANUTENZIONE E VERIFICHE PRELIMINARI

Perchè il suo apparecchio funzioni nella maniera corretta e possa durare nel tempo, occorre che vengano rispettate le modalità di installazione e manutenzione illustrate in questo opuscolo. Affidarsi ad un idraulico qualificato. Assicurarsi che l'impianto sia stato liberato da tutti i detriti e impurità esistenti.

Si raccomanda di utilizzare un riduttore di pressione, se all'interno dell'impianto si hanno pressioni statiche superiori a 5 BAR.

Si raccomanda anche l'utilizzo di un addolcitore.

INSTALLAZIONE

Fig. 1 / 3: Posizionare il corpo miscelatore nell'alloggiamento realizzato nella parete, ponendo particolare attenzione ai riferimenti per la posa MIN e MAX stampati sul carter di protezione. **N.B.:** i riferimenti MIN e MAX sono intesi a parete finita, compreso di rivestimento.

Fig. 2: Estrarre i tappi in plastica ed allacciarsi alle tubazioni della rete idrica. é consigliabile utilizzare PTFE per garantire la tenuta al filetto.

Fig.4: Stabilizzare il corpo all'interno della parete individuando, con l'ausilio di una livella a bolla, il corretto posizionamento.

Fig. 5: Dopo aver collegato il corpo incasso all'impianto, aprire i rubinetti d'arresto e verificare la mancanza di perdite nei collegamenti all'impianto.

Fig. 6a / 6b: Completati i lavori richiudere i rubinetti d'arresto non lasciando l'impianto in pressione. Svitare le viti del carter ed estrarlo.

Fig. 7: Svitare le viti e smontare il tappo piatto. **ATTENZIONE:** non buttare le 4 viti, serviranno nuovamente.

Fig. 8: Avvitare il Kit di montaggio acquistato separatamente (INC406XXXN_0).

Fig. 9-10-11: Per parete senza piastrelle, murare l'incasso diminuendo le dimensioni fino a filo di ingresso bocca e maniglia utilizzando la dima fornita in dotazione.

Fig. 12-13-14: Per parete con piastrelle, utilizzare la dima per eseguire due fori sulla piastrella dedicata. Utilizzare una livella a bolla per garantire il corretto posizionamento.

Completati i lavori tenere SEMPRE chiusi i rubinetti d'arresto lasciando l'impianto senza pressione.

Fig. 15-16: ATTENZIONE: Verificare a parete finita, compreso di rivestimento, di rientrare nelle misure minime e massime indicate sul carter tondo. Se non sono stati rispettate le misure indicate sul carter, contattare l'assistenza per un Kit di estensione.

L'impermeabilizzazione del muro a discrezione dell'installatore.

TECHNICAL DATA

Minimum dynamic pressure: 0.5 bar

Maximum operational pressure: 5 bar

Recommended operational pressure: 1-5 bar

Maximum hot water temperature: 80°

INSTALLATION, MAINTENANCE AND PRELIMINARY CHECKING PROCEDURE

To ensure that the mixer tap unit functions correctly and lasts over time, the installation and maintenance procedures illustrated in this leaflet must be complied with. Have all work done by a qualified plumber. Ensure that all debris and dirt have been removed from the system.

It is recommended to use a pressure reducer, if inside the waterpipes there are static pressure superior 5 bar.

The use of a water softener is recommended.

INSTALLATION

Fig. 1 / 3: Position the mixer body in the housing made in the wall, paying particular attention to the MIN and MAX installation references printed on the protective casing.

N.B.: the MIN and MAX references are intended for the finished wall, including covering.

Fig. 2: Remove the plastic caps and connect to the water mains pipes. It is advisable to use PTFE to guarantee the seal on the thread.

Fig.4: Stabilize the body inside the wall, identifying the correct positioning with the aid of a spirit level.

Fig. 5: After having connected the built-in body to the system, open the stop cocks and check for lack of leaks in the connections to the system.

Fig. 6a / 6b: Once the work is completed, close the stop cocks without leaving the system under pressure. Unscrew the crankcase screws and remove it.

Fig. 7: Unscrew the screws and remove the flat cap. **ATTENTION:** do not throw away the 4 screws, they will be needed again.

Fig. 8: Screw the mounting kit purchased separately (INC406XXXN_0).

Fig. 9-10-11: For walls without tiles, wall the recess by decreasing the dimensions to the level of the mouth and handle entry using the template supplied.

Fig. 12-13-14: For a wall with tiles, use the template to make two holes on the dedicated tile. Use a spirit level to ensure correct positioning.

Once the work has been completed, ALWAYS keep the stop cocks closed, leaving the system without pressure.

Fig. 15-16: ATTENTION: Check that the finished wall, including covering, falls within the minimum and maximum measurements indicated on the round casing. If the measurements indicated on the crankcase have not been respected, contact assistance for an extension kit.

The waterproofing of the wall is at the discretion of the installer.

CARATÉRISTIQUES TECHNIQUES

Pression dynamique mini: 0.5 bar
Pression maxi d'exercice: 5 bar
Pression d'exercice recommandée: 1-5 bar
Température maxi eau chaude: 80°

NORMES D'INSTALLATION, D'ENTRETIEN ET VÉRIFICATIONS PRÉLIMINAIRES

Pour que votre appareil fonctionne correctement et dure dans le temps, il est nécessaire de respecter les modalités d'installation et d'entretien illustrées dans cet opuscule. Demander l'intervention d'un plombier qualifié. Vérifier que l'installation est libre de tous détritres et de toutes impuretés.

Il est recommandé d'utiliser un réducteur de pression en cas de pressions statiques supérieures à 5 bar.

L'utilisation d'un adoucisseur est également recommandée.

INSTALLATION

Fig. 1 / 3 : Positionner le corps du mitigeur dans le logement réalisé dans le mur en faisant particulièrement attention aux références d'installation MIN et MAX imprimées sur le boîtier de protection. **N.B.** : les références MIN et MAX sont destinées au mur fini, revêtement compris.

Fig. 2 : Retirez les capuchons en plastique et raccordez-les aux conduites d'eau principales. Il est conseillé d'utiliser du PTFE pour garantir l'étanchéité sur le filetage.

Fig.4 : Stabiliser le corps à l'intérieur du mur en identifiant le bon positionnement à l'aide d'un niveau à bulle.

Fig. 5 : Après avoir raccordé le corps encastrable à l'installation, ouvrir les robinets d'arrêt et vérifier l'absence de fuites dans les connexions à l'installation.

Fig. 6a / 6b : Une fois les travaux terminés, fermer les robinets d'arrêt sans laisser le système sous pression. Dévissez les vis du carter et retirez-le.

Fig. 7 : Dévissez les vis et retirez le capuchon plat. **ATTENTION** : ne jetez pas les 4 vis, elles seront à nouveau nécessaires.

Fig. 8 : Vissez le kit de montage acheté séparément (INC406XXXN_0).

Fig. 9-10-11 : Pour les murs sans carrelage, murez la niche en diminuant les dimensions jusqu'au niveau de l'embouchure et manipulez l'entrée à l'aide du gabarit fourni.

Fig. 12-13-14 : Pour un mur avec du carrelage, utilisez le gabarit pour réaliser deux trous sur le carrelage dédié. Utilisez un niveau à bulle pour garantir le bon positionnement.

Une fois les travaux terminés, TOUJOURS garder les robinets d'arrêt fermés, laissant le système sans pression..

Fig. 15-16 : **ATTENTION** : Vérifiez que le mur fini, y compris le revêtement, respecte les mesures minimales et maximales indiquées sur le boîtier rond. Si les mesures indiquées sur le carter n'ont pas été respectées, contacter l'assistance pour un kit d'extension. L'imperméabilisation du mur est au gré de l'installateur.

Per parte esterna (For external part) 406 / 407

Fig. 1

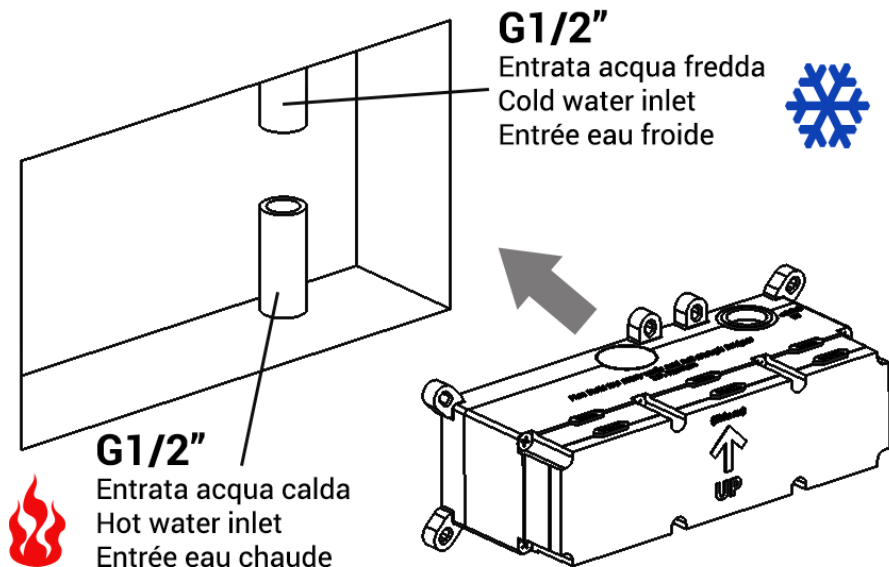
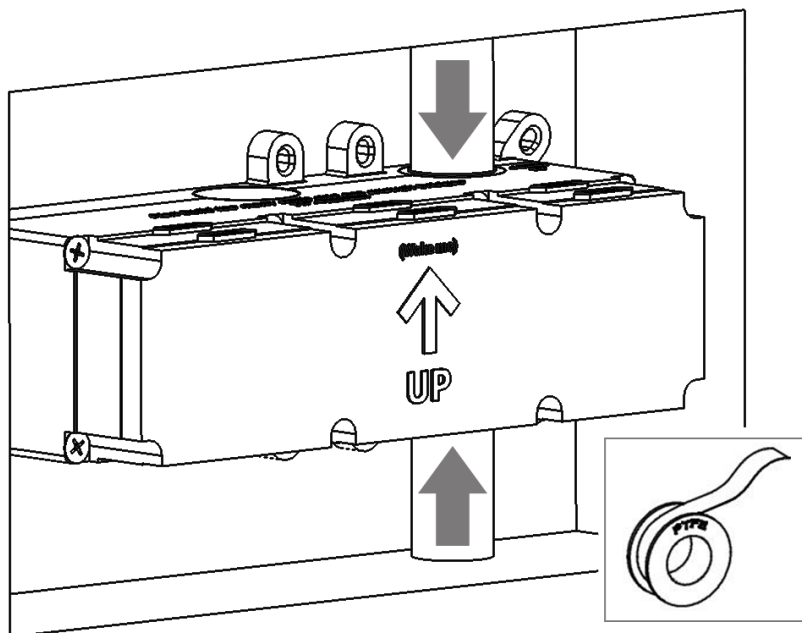
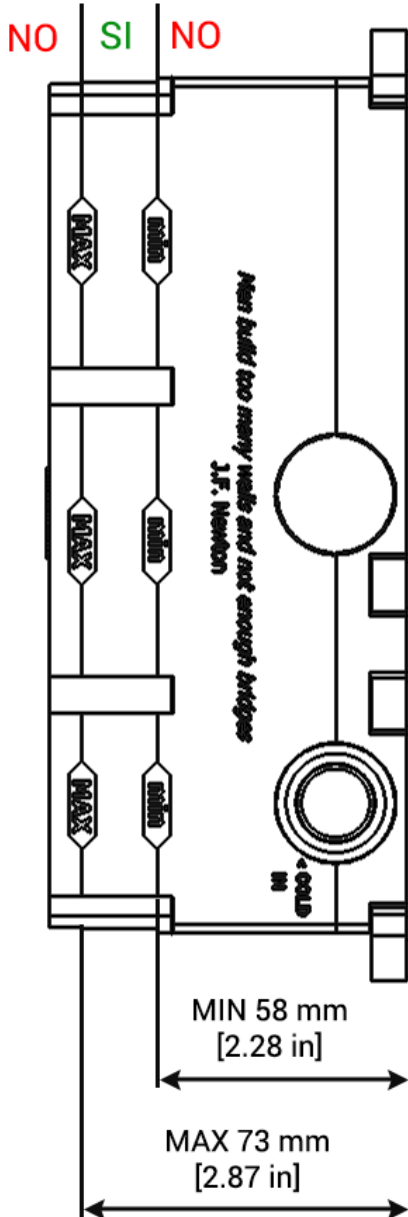

Fig. 2



Per parte esterna (For external part) 406 / 407

Fig. 3



Per parte esterna (For external part) 406 / 407

Fig. 4

SI, YES, OUI

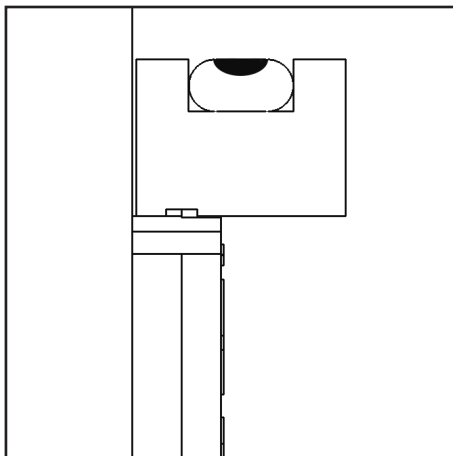
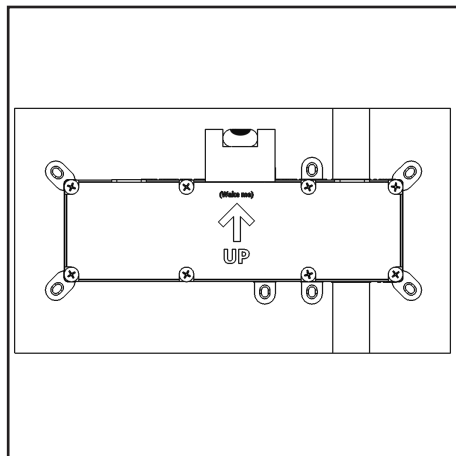

NO

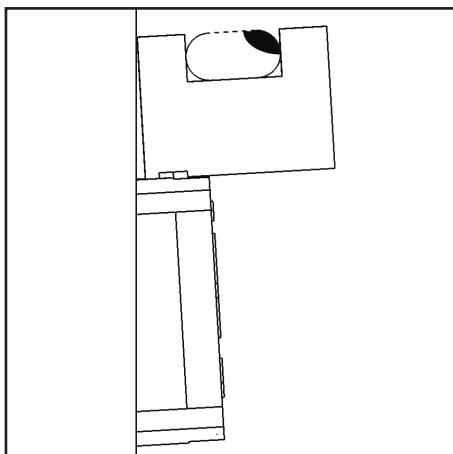
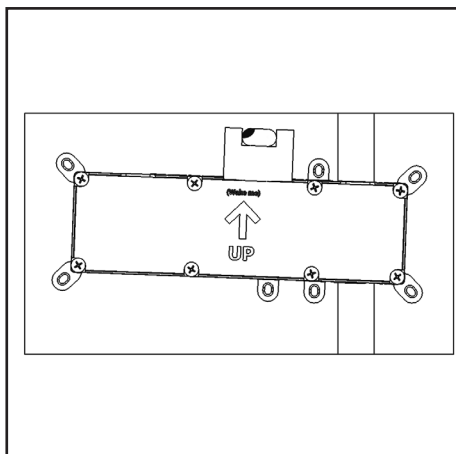

Per parte esterna (For external part) 406 / 407

Fig. 5

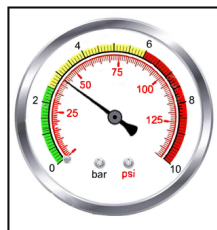
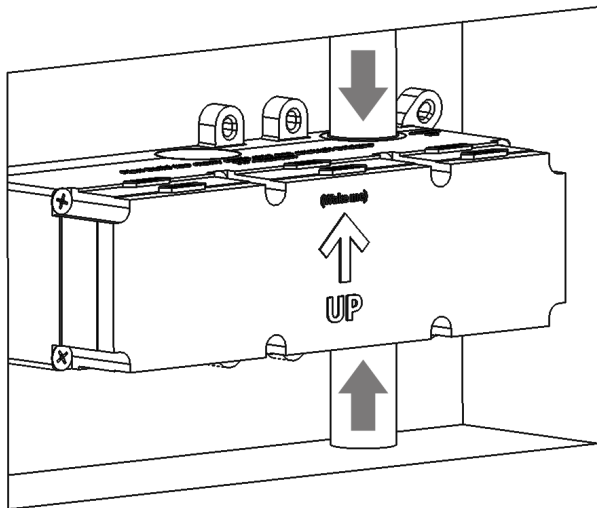
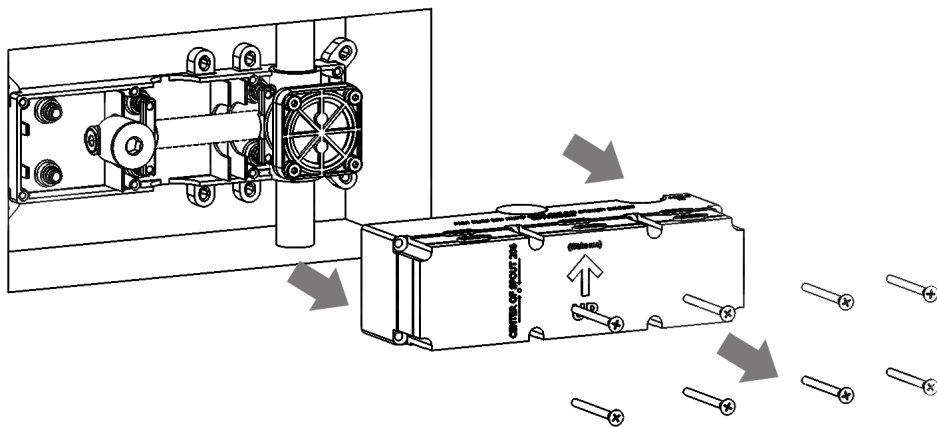
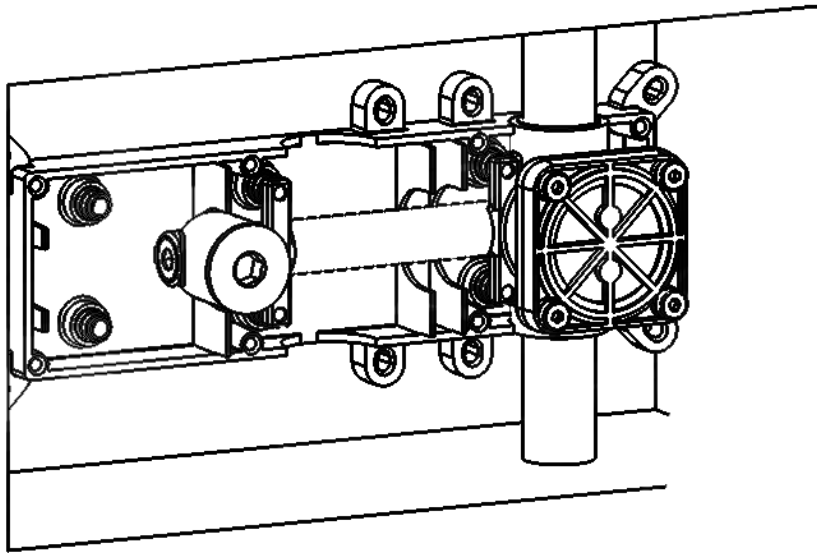

Fig. 6a



Per parte esterna (For external part) 406 / 407

Fig. 6b



Tenere SEMPRE chiusi i rubinetti d'arresto lasciando l'impianto senza pressione

ALWAYS keep the stop cocks closed leaving the system without pressure

TOUJOURS garder les robinets d'arrêt fermés en laissant le système sans pression



Per parte esterna (For external part) 406 / 407

Fig. 7

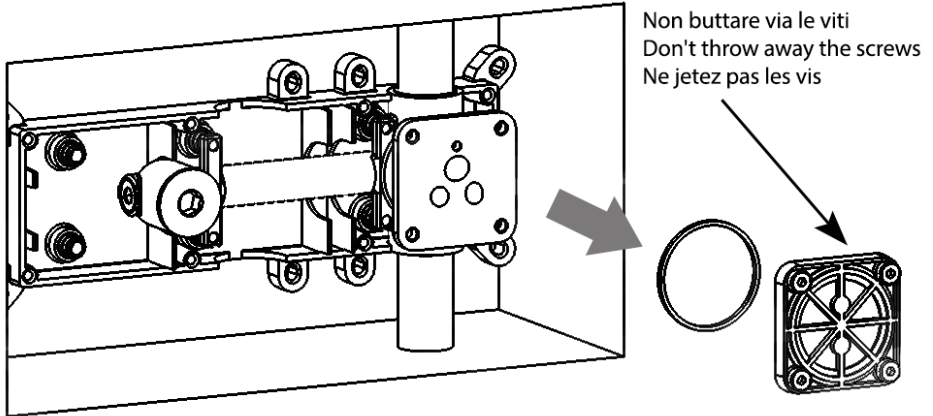
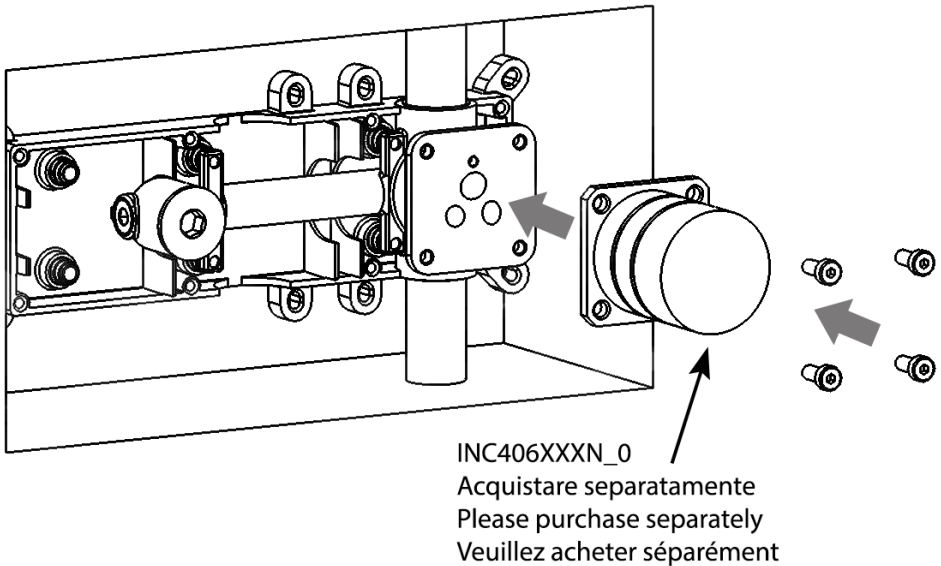
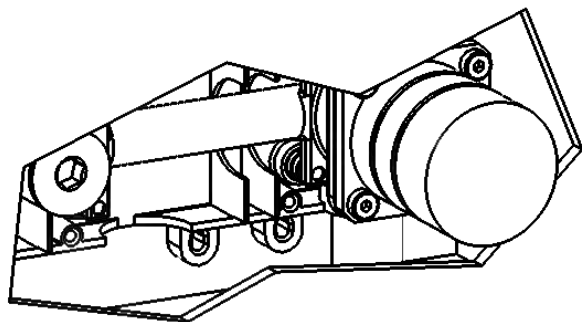

Fig. 8



Per parte esterna (For external part) 406 / 407

Fig. 9



Muro senza piastrella
Wall without tile
Mur sans carrelage

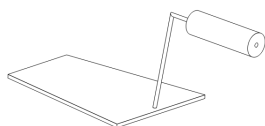

Fig. 10

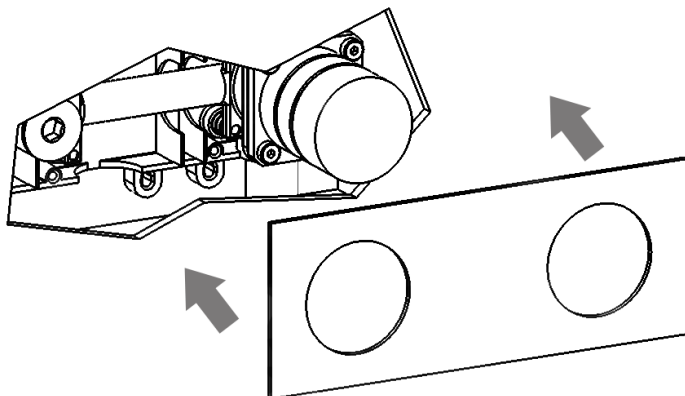
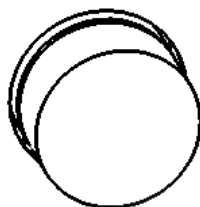
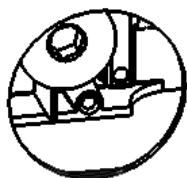

Fig. 11

Risultato finale
Final results
Résultats finaux



Per parte esterna (For external part) 406 / 407

Fig. 12

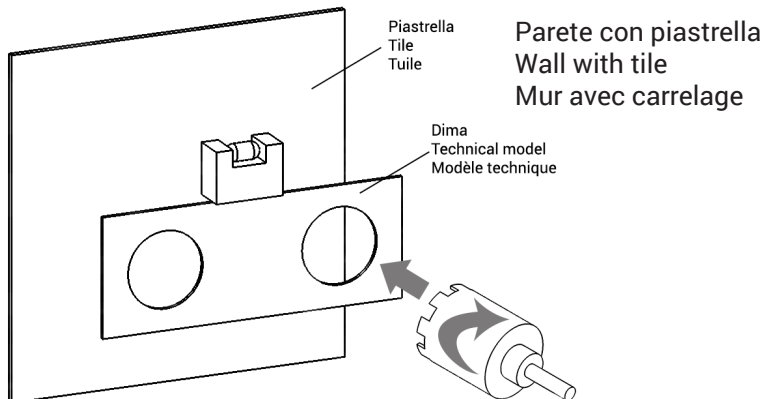

Fig. 13

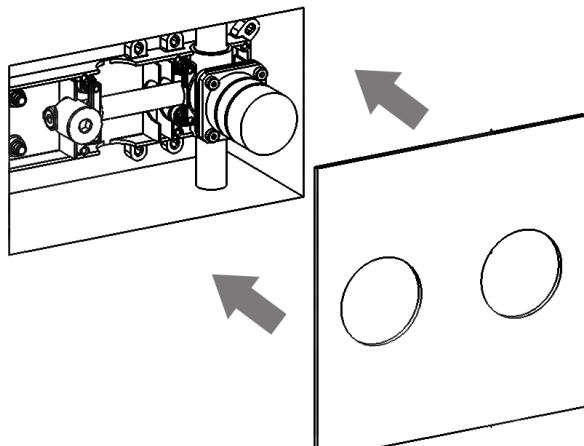
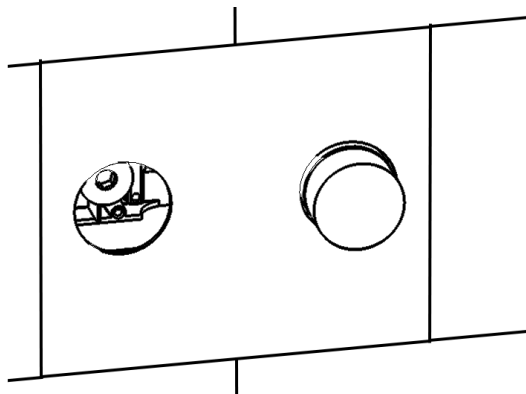

Fig. 14a

Risultato finale
Final results
Résultats finaux



Per parte esterna (For external part) 406 / 407

Fig. 14b

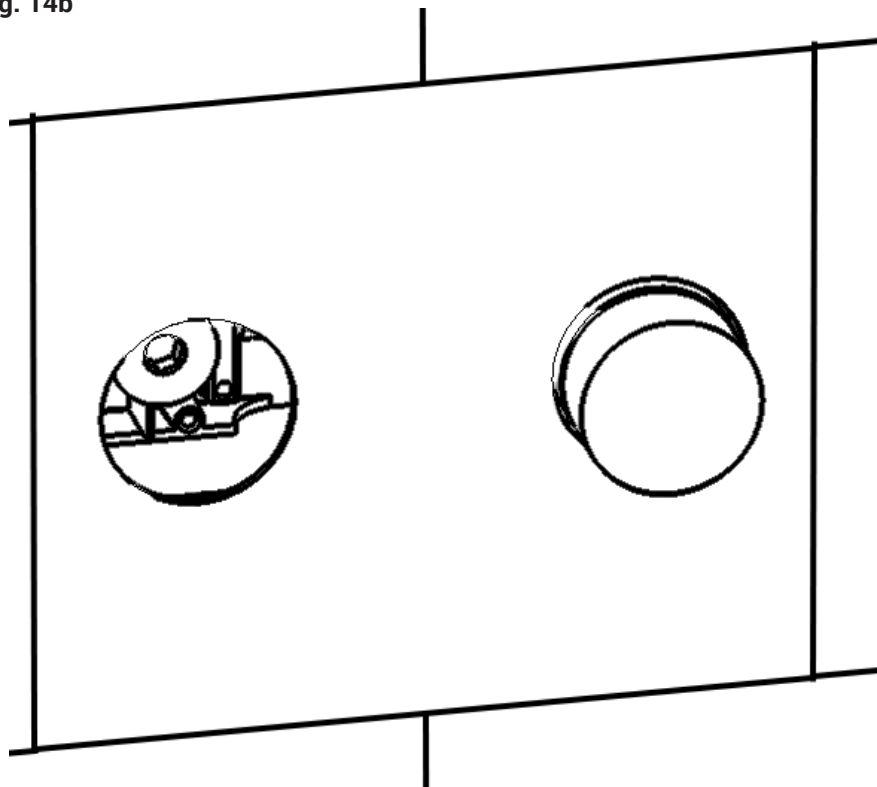

Per parte esterna (For external part) 406 / 407

Fig. 15

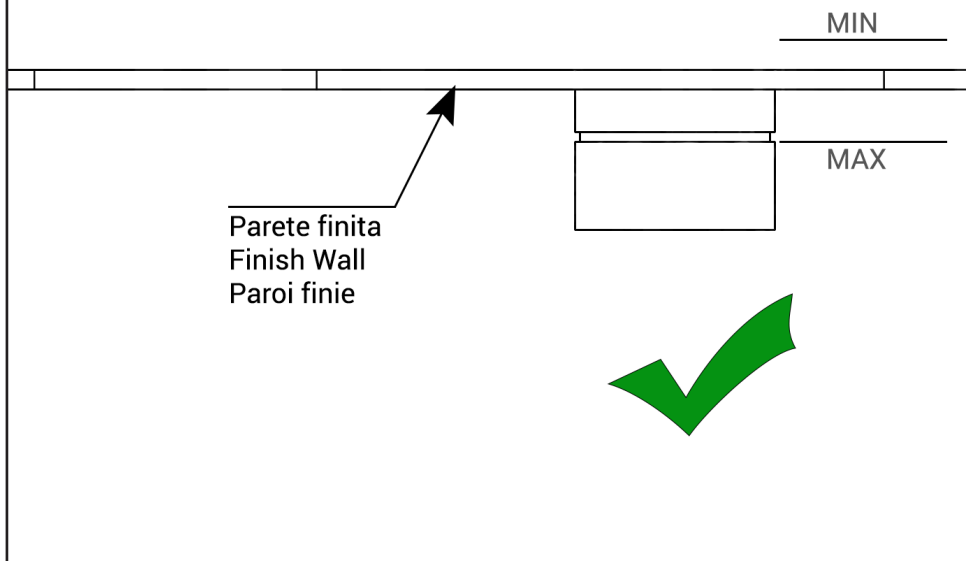
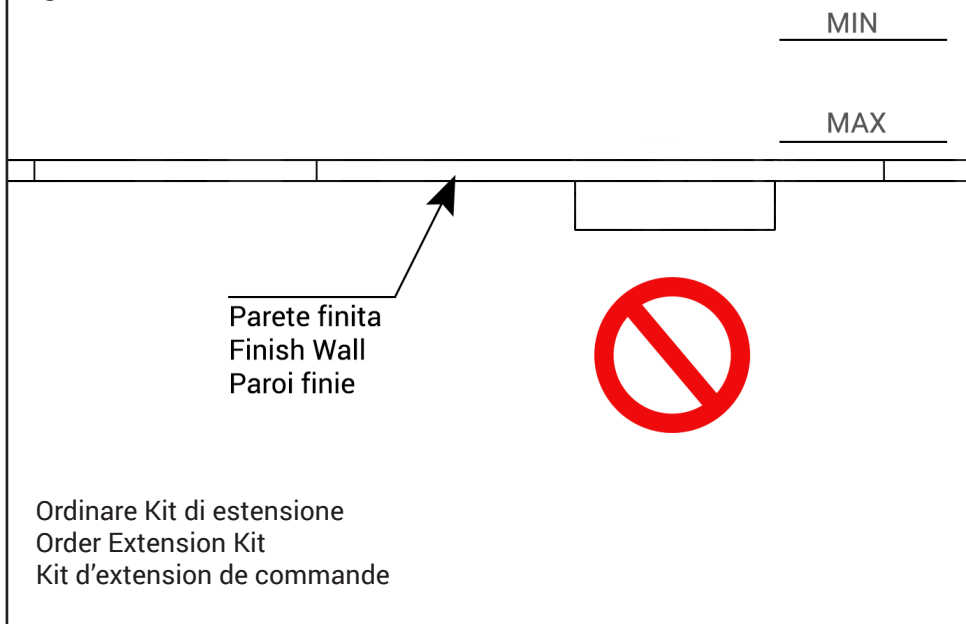
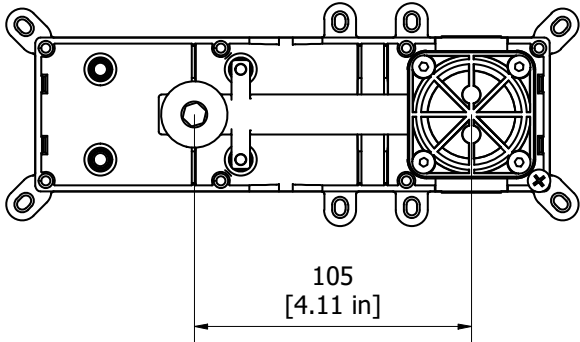
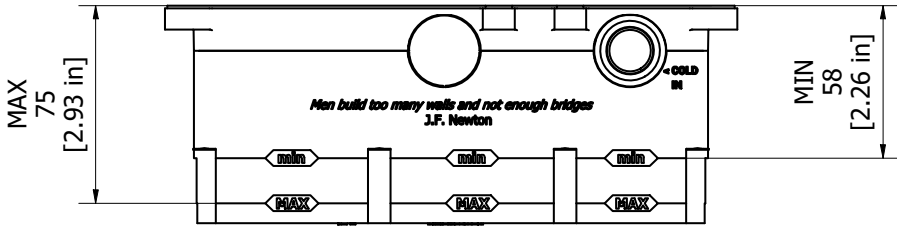
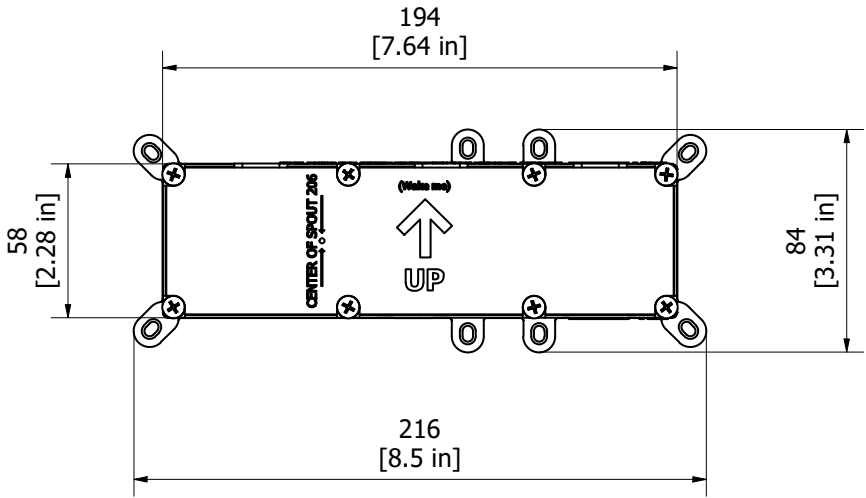

Fig. 16





Rev. 27/09/2023

IMPORTANT

Pressure & Temperature Requirements.

- ❖ Hot and cold water inlet pressures should be equal.
- ❖ Inlet pressure range: 150-1000 kPa
- ❖ New Regulation: -500 kPa maximum operating pressure at any outlet within a building (Ref. AS/NZS 3500.1-2003, Clause 3.3.4)
- ❖ Maximum hot water temperature: 80°C.



WE ARE IB

IB RUBINETTERIE s.p.a
via dei Pianotti 3/5
25068 Sarezzo (BS) - Italy -
P.IVA 01785230986

ISCR. REG. IMPR.
BS 01785230986
R.E.A. BS 352087
capitale sociale €420.000,00 i.v.

T. +39 030 802101
F. +39 030 803097
info@weareib.it
www.weareib.it